

Thermic Mobile Hot Cabinet

Commercial Food Service Units



Controller with digital display



Water pan for additional moisture



GN Pan tray slide



Ergonomic handle for easy maneuverable



Circulating fans for even temperature



Magnetic door latch



Thermic Mobile Hot Cabinet



Somerville (SIAM) LIMITED.

SINCE 1958

THE PROFESSIONAL COMMERCIAL KITCHEN & BAKERY SPECIALIST



15 Moo 14 Bangna-Trad Highway Km.10, Bangplee Yai, Samutprakarn 10540, Thailand Tel : 66 2 316 0751-7 Fax : 66 2 316 0772
Email : salesdept@somerville-siam.com, adms@welbilt-thailand.com www.somerville-siam.com, www.somervillecompanies.com

CAT-0409-01



Thermic Mobile Hot Cabinet



Provide easy mobility to transport food from kitchen to dining area and maintain it at hot serving temperature, until ready to be served. Dual heating elements for fast temperature recovery. Refillable water pan to supply additional moisture, if needed. All around hard rubber bumper and to minimize accidental damage.

New stainless steel handle design for better mobility control. Adjustable digital controller for precise temperature setting. Double circulating fan providing even temperature throughout the cabinet. Angle slides to accommodate standard gastronorm pan depth, plates or other stored items.

STANDARD FEATURES

- Foamed-in-place, fully insulated hot cabinet keeps prepared food at serving temperatures.
- Dual heater (2x750 watts) to maintain temperature between 30° C to 99° C and fast recovery after door opening.
- Digital controller with LED display for ease of temperature adjustment and monitoring.
- Refillable water pan to provide additional moisture.
- Stainless steel internal frame. Stainless steel exposed surface for durability against food acidity.
- Food grade high temperature door gaskets for proper seal and durability.
- Smooth interior with internal coved corner for easy cleaning.
- Stainless steel handle design for better mobility control.
- Magnetic door latches to secure doors during cabinet movement.
- Flush mounted hinges, with left hand or right hand door opening selection.
- All around hard rubber bumper
- Completed with 6 sets of tray slides suitable for standard GN1/1 and/or GN 2/1 pans
- Tray slide slots are adjustable for different tray depths, plated or other stored items.
- Heavy duty 5" Swivel casters with two lockable brakes.
- Isolated electrical circuits.
- Earthed grounded preventing electrical hazard.

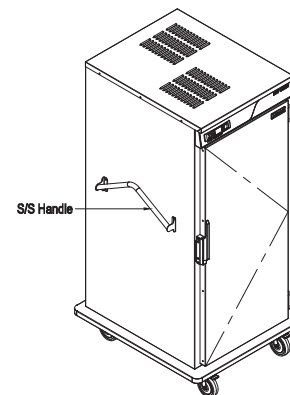

ISOMETRIC VIEW

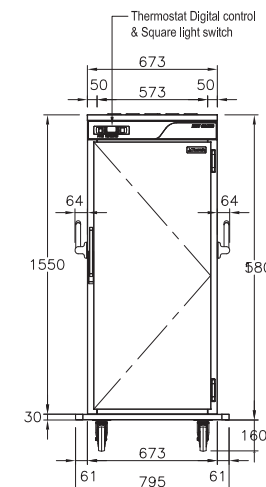

FRONT VIEW

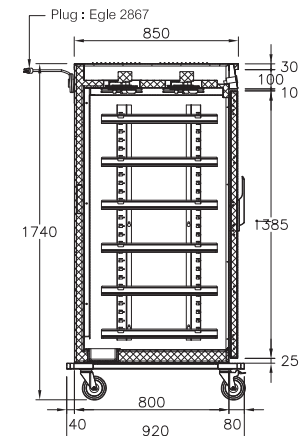

SIDE VIEW

