

Parts Exploded View



Doing our part in keeping working place safe and our environment clean.



Dealer :

Continued product improvement is **Somerville GROUP** policy. Specifications are subject to change without notice.

Somerville
**Grating &
Drain Trough**



Available in two models. DN 70, DN 100

SM-GDT-0509-01

Model : DN 70



Grating & Drain Trough



Model : DN 100

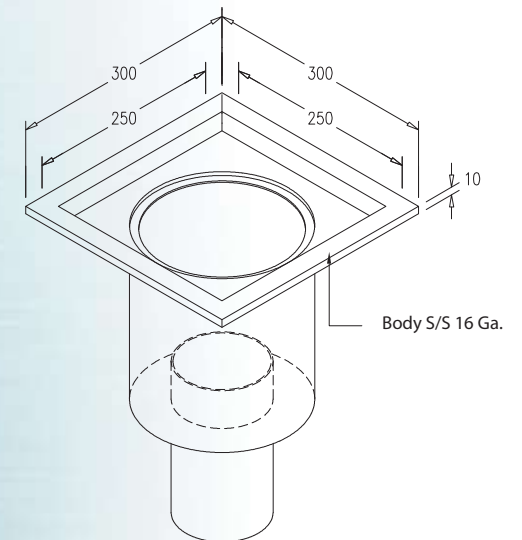
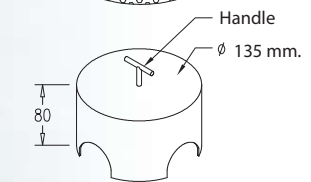
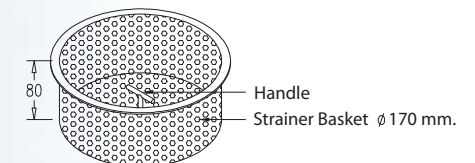
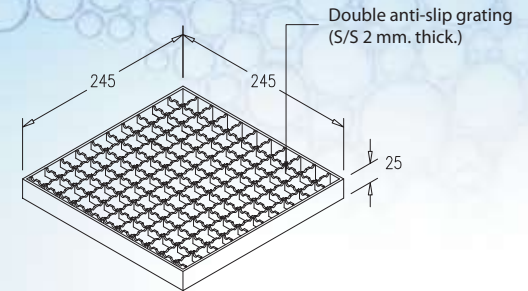
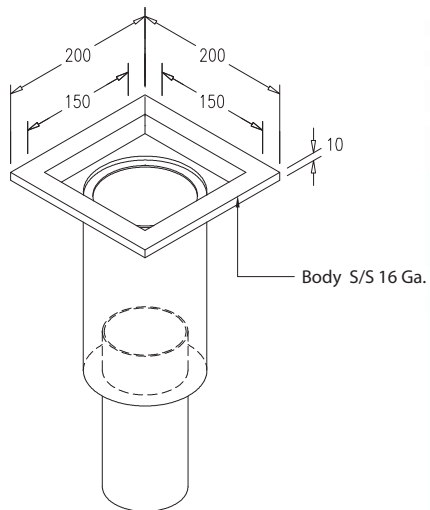
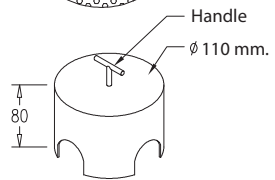
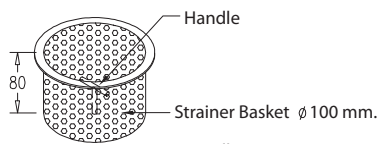
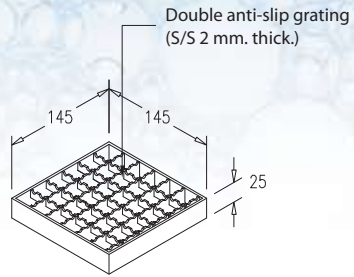

- ▶ Durable high quality, all Stainless Steel construction.
- ▶ Laser etched and fabricated with precision.
- ▶ Prevent clogged drain line, yet easy to clean.
- ▶ Anti-slip.

