

C-CT-SERIES » Counter top heated / ambient display showcase.



Detail : 1



Detail : 2

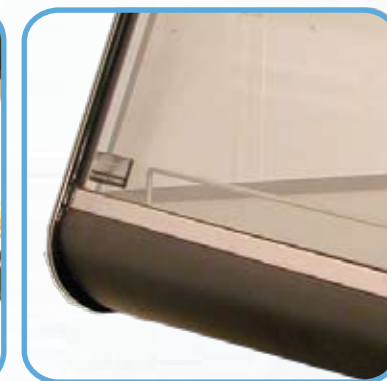

Detail : 3

Attractive counter top pastry display.

STANDARD FEATURES

Construction	Tough, hygienic construction, with the choice of warm or ambient models to suit your application. Contemporary design with slanted front glass and light to visibly display your product. Charcoal powder coated finish.	
Glass	Double glazed reflective glass panels side and front with front panel heated.	
Doors	Rear roller sliding glass door.	
Heated unit	Keep product fresh without excessive drying with unique moisture retention and holding system. Water pan is easily removable for cleaning.	
Ambient unit	Same as hot display unit but without heater system. Display product at ambient temperature.	
Shelves	Complete with 2 adjustable stainless steel wire shelves.	
Optional extra	Stainless steel exterior or choice of exterior powder coated paint to enhance your store color profile. Square front glass instead of slanted. Rear double glazed reflective sliding door with mirror film.	

Dimension :

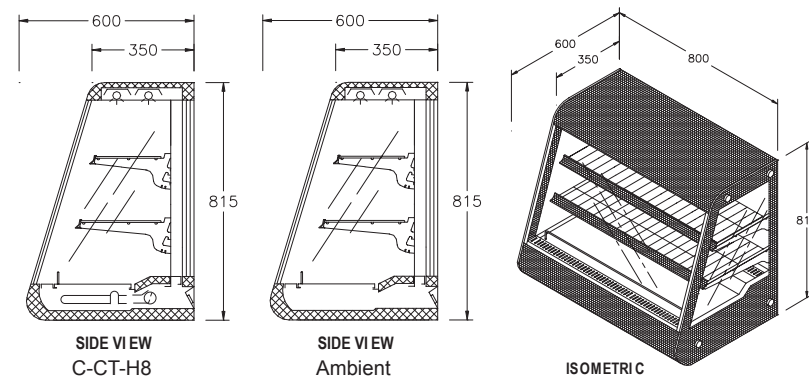

TECHNICAL DATA

Model number	C-CT-H8	C-CT-A8
Dimension - LxDxH (mm.)	800 x 600 x 815	800 x 600 x 815
Temperature range	35 °C to 80 °C	Ambient
Power supply	220 W / 50 Hz / 1 Ph (60 Hz models are available.)	

Dealer :



Continued product improvement is **WELBILT** Manufacturing (Thailand) Ltd., policy. Specifications are subject to change without notice.