



C-CT-R8

Elegant counter top drop-in refrigerated display.



Detail : 1



Detail : 2



Detail : 3



Detail : 4

» STANDARD FEATURES

Construction	Tough, hygienic construction, with the choice of refrigerated, warm or ambient models to suit your application.
Glass	Front heated double glazed reflective glass panel. Side and back glasses are single pane.
Doors	Rear roller sliding glass door.
Refrigerated unit	Reliable, self-contained system, designed to drop in on top of the counter. Refrigerated model has condensing unit extended under the counter to maximise product display space. Fitted with condensate evaporator, no drain connection required. CFC free R404a refrigerant.
Controller	Multi-function microprocessor controlled with digital thermometer display.
Shelves	Complete with 2 adjustable stainless steel wire shelves.
Optional extra	Stainless steel exterior or choice of exterior powder coated paint to enhance your store color profile. Square front glass instead of slanted. Rear double glazed reflective sliding door with mirror film.

Dimension :

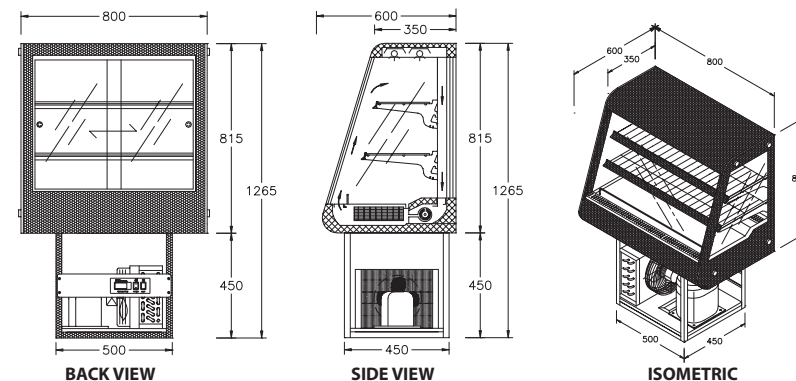

» TECHNICAL DATA

Model number	C-CT-R8
Dimension - LxDxH (mm.)	800 x 600 x 1265
temperature range	2 °C to 5 °C
Power supply	220 W / 50 Hz / 1 Ph (60 Hz models are available.)

Dealer :

