

# KOLDTECH

The Technology of Excellence

# Display Showcase

## DTRCD-SERIES » Dual-temp Display showcase

DTRCD-R7-A7-1530



Attractive design dual temperature display.

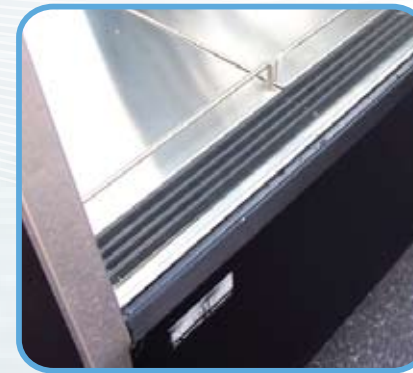

Detail : 1



Detail : 2



Detail : 3

Dimension :

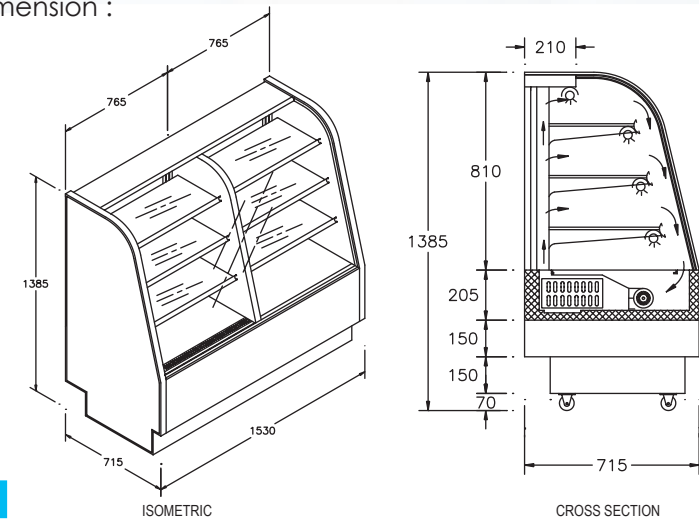

### STANDARD FEATURES

Refrigerator system	Self-contained, bottom mounted, using R134a as refrigerant. (for refrigerated section)
Controller	Multi-function microprocessor controlled with digital temperature display and automatic humidity control.
Body & furnishing	Rust proof steel structure. Polyurethane Foamed-in-place insulated side and bottom panels. Double pane insulated front curvature glass, double pane glass sliding door in the back with reflective film to highlight the product. Fluorescent light to increase product visibility. Choice of 70 mm caster wheel or adjustable bullet feet.
Shelves	Fully adjustable glass shelves with polished stainless steel shelf supports.

### TECHNICAL DATA

	Refrigerated Compartment	Ambient Compartment
Model number	DTRCD-R7-A7-1530	
Dimension - LxDxH (mm.)	1530 x 715 x 1390	
Temperature range	2 °C to 5 °C	Ambient
Cooling capacity (Btu.)	4947	-
Compressor (Hp.)	3/4	3/4
Refrigerant	R-404a - CFC free	-
Glass shelves	6	6
Display light (w)	4 x 15 watts	4 x 15 watts
Power supply	220 / 50 / 1Ph. / 3 Amps. (60 Hz models are available.)	
Optional extra	Additional shelf with lighting.	

Dealer :



CERTIFICATE NO. 54705



CERTIFICATE NO. 35613

Continued product improvement is **WELBILT** Manufacturing (Thailand) Ltd., policy. Specifications are subject to change without notice.

CAT-DTRCD-0308-02