

# KOLDTECH

The Technology of Excellence

# Display Showcase

## SQRCD-SERIES » Square showcase unit

SQRCD-12



Contemporary multi-purpose display showcase.



Detail : 1

Unique low velocity air flow designs that cool product without excessive drying, prolonging freshness and shelf life.



Detail : 2

Recycled warm air blowing over exterior glass to prevent condensation, providing clear view of products.

### STANDARD FEATURES

Refrigerator system	Uniquely designed to have cold air floating beneath each shelf with very little air movement, therefore extending shelf life without drying out the product. Reliable self contained, bottom mounted, system, designed for tropical climate and easy servicing. Using R-134a as refrigerant. Drainage connection not necessary, as system uses condensate evaporator.
Controller	Multi-function microprocessor controlled with digital temperature display to monitor and control cabinet temperature.
Body and furnishing	Stainless steel base and top. Polyurethane foamed-in-place insulated bottom panels (40 mm.) Double glazed heat reflective front and side glasses to provide grand outlook. Self closing rear sliding doors with mirror finish and fluorescent light fixtures to emphasize and increase product visibility.
Shelves	Two non adjustable stainless steel shelves and shelf supports.
Other features	78 mm high swivel casters.

### Dimension :

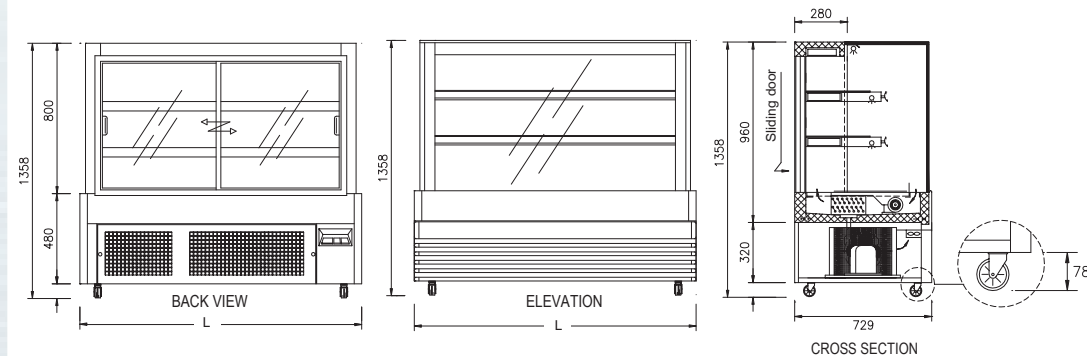

### TECHNICAL DATA

Model number	SQRCD - 12	SQRCD - 15	SQRCD - 18	SQRCD - 20
Dimension L x D x H (mm.)	1200 x 729 x 1358	1500 x 729 x 1358	1800 x 729 x 1358	2000 x 729 x 1358
Temperature range	2°C to 8°C			
Cabinet capacity Cu.Ft./ Litres	18.5/525	23.8/673	29/820	32.4/918
Compressor (Hp.)	3/4	3/4	1	1
Display light (w)	30 x 3	36 x 3	58 x 3	58 x 3
Power supply	220 / 50 / 1 Ph. (60 Hz models are available.)			

Dealer :

Continued product improvement is **WELBILT** Manufacturing (Thailand) Ltd., policy. Specifications are subject to change without notice.



CAT-SQRCD-0308-03