

From 48 Kg to 160 Kg of dough

PCM x L



4 models from 48 to 160 Kg of dough

2 speeds
2 Timers
Removable stainless steel free bowl
Cast aluminium fork
Unibody structure
Bowl brake
Lifting head
Stainless steel raising safety grid
Floor vat

Electromecanic control panel
Emergency stop button

OPTION :
Additional bowl

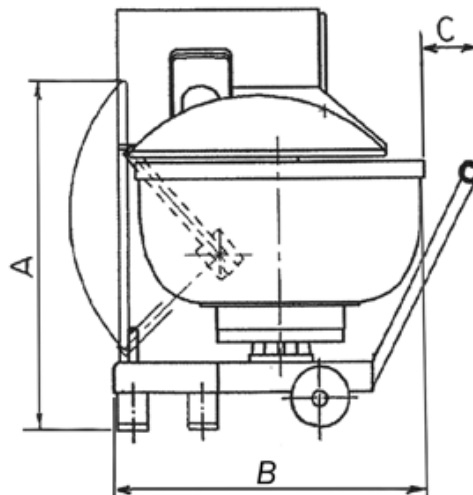
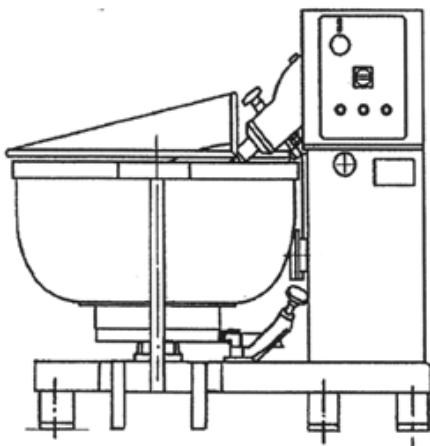

MODEL	PCM 18 L	PCM 30 L	PCM 45 L	PCM 60 L
Dimensions				
A mm	875	1030	1115	1200
B mm	720	930	1005	1080
C mm	280	200	150	100
Weight				
Kg	480	500	520	540
Capacity				
Bowl Kg	95	170	230	330
Pouring (mini/maxi) L	6/18	10/30	15/45	20/60
Flour (mini/maxi) Kg	10/30	18.5/50	25/75	33/100
Dough Kg	48	80	120	160
Power Motor				
(kW)	2.2	5.5	5.5	5.5
Power Tool				
1st speed (rpm)	48			
2nd speed (rpm)	72			
Voltage				
.	TRI - 400 V - 50Hz+T+N			