

ELECTRIC , GAS OR FUEL- 600 X 800 mm
FRP 6/8 R



Energy : Electricity, gas or fuel

- Digital control panel
- Digital panel for temperature
- Timer
- Steamer
- Hood included
- Trolley fixed by hook system
- Independent trolley motor
- Safety thermostat
- Expansion valves

- Glass wool isolation
- Stainless steel front side
- Glass with wide window

- Supply not assembled
- Supply without burner

OPTIONS :

- Assembling
- Burner fuel or gas
- Trolley
- Grids
- Baking trays
- Trays

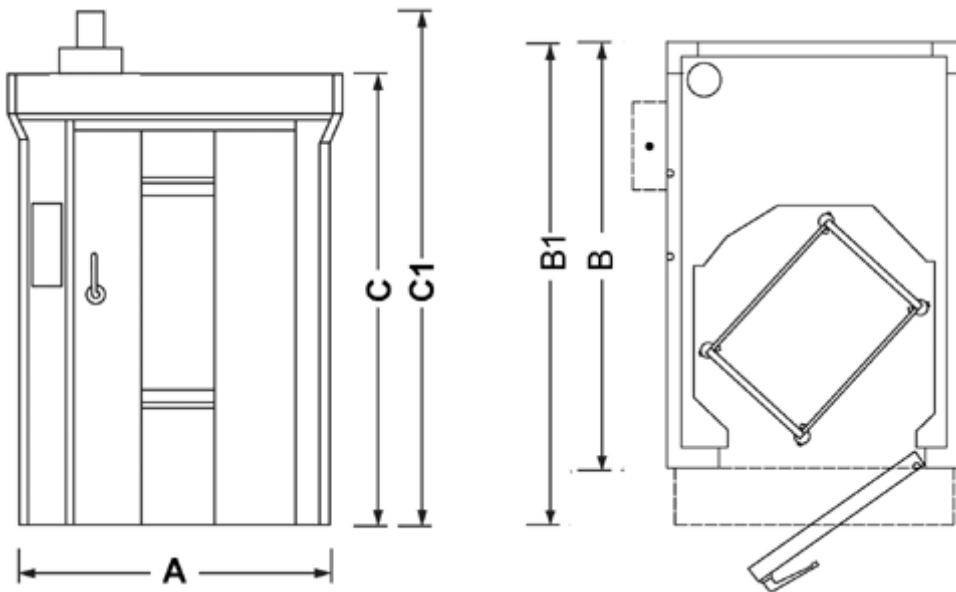

MODEL	FRP6/8 RE	FRP6/8 RF	FRP6/8 RG
Energy			
	Electricity	Fuel-oil	Gas
Dimensions			
A mm	1460		
B mm	2230		
B1 mm	2430		
C mm	2300		
C1 mm	2550		
Weight			
Kg	1020	990	990
Power			
Satrt	45	6 Kg / h	5.6 m ³ / h
Maintenance	15	2.5 kg / h	2 m ³ / h
Voltage			
.	TRI - 400 V - 50 Hz + N		